

# BAG AND CLIP TRANSPORTER

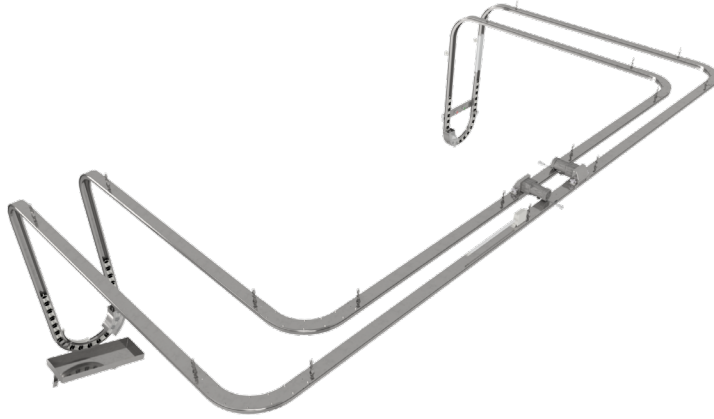

<b>Item #:</b>
<b>Project:</b>
<b>Quantity:</b>

## PRODUCT OVERVIEW

Bag & Clip Transporters are customized transporting system using clips to carry bags containing food products from a loading point to a remote delivery point, either on the same floor or on a different level. Track system is typically suspended under the ceiling or enclosed above the ceiling.

## STANDARD PRODUCT FEATURES

- Aluminum, stainless steel, and plastic design ensures easy cleaning and maintenance
- Customized design to best suit the unique project requirement - enable a challenging site layout, build "to go" kiosks at street level or limit DT footprint.
- Efficient and hygienic delivery system moves multiple products between building floors within seconds
- Modular track design ensure flexibility to meet any site conditions and ease of installation
- Lightweight design and low-power motor reduces power consumption
- Built-in safety features and emergency shut-off system ensure safe operation of system at all times
- Includes spare parts box with critical parts for peace of mind

BAG AND CLIP TRANSPORTER



FOR COMMERCIAL USE ONLY

Franke Foodservice Systems Inc  
800 Aviation Parkway  
Smyrna, TN 37167  
Tel +1-877-379-3769  
franke.com

*Make  
it  
Wonderful*



# BAG AND CLIP TRANSPORTER

ISOMETRIC VIEW

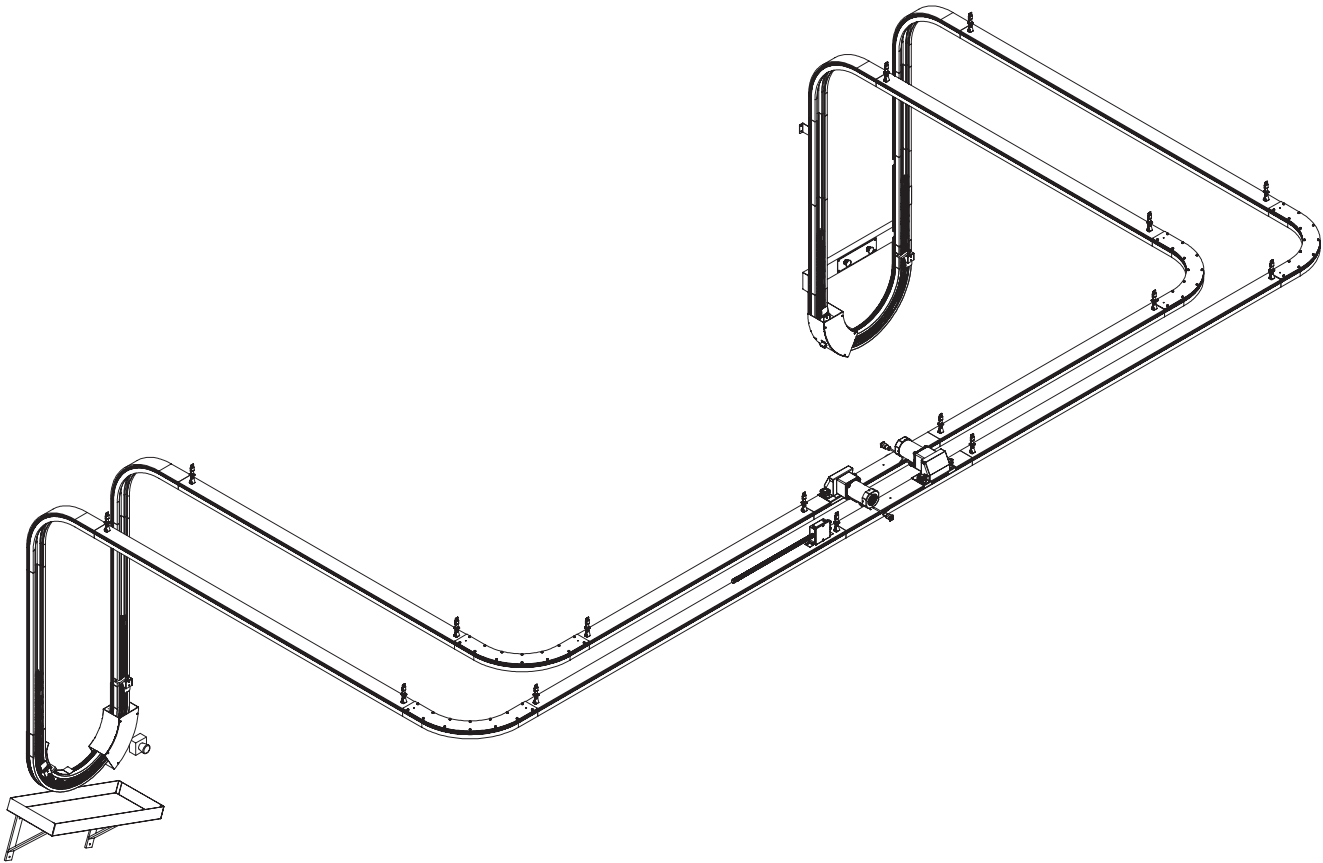

## DIMENSIONS

Track Length	32.8' - 328.0'	10.0 m - 100.0 m
Number of Clips	4 (Minimum) - 40 (Maximum)	
Max. Payload per Clip	4.4 lbs	2.0 kg
System Deadweight	260 lbs - 1650 lbs	120 kg - 750 kg

## ELECTRICAL

Voltage/Frequency/Phase	115-230V/50-60Hz/1Ph	
Power	½ HP	0.4 kW
Motor	AC Gearhead Drive Motor	
Motor Power Load	1.2 A	
System Speed	2.6 ft/s - 4.76 ft/s	0.8 m/s - 1.45 m/s

 **RECYCLE DOCUMENTS AND EQUIPMENT RESPONSIBLY**

© 2020 Franke Foodservice Systems, Inc. This media is the confidential and proprietary property of Franke Foodservice Systems, Inc. and shall not be reproduced in any form of media without the express written permission of a Franke representative. Due to continuous product development, Franke reserves the right to make changes in design and specifications without prior notice. Under license Franke Technology and Trademark Ltd., Switzerland. Printed in USA. Document Part # 19015614, Rev. A, June 16, 2020

*Make it Wonderful*

